

ASME B16.34 1-PIECE REDUCED BORE

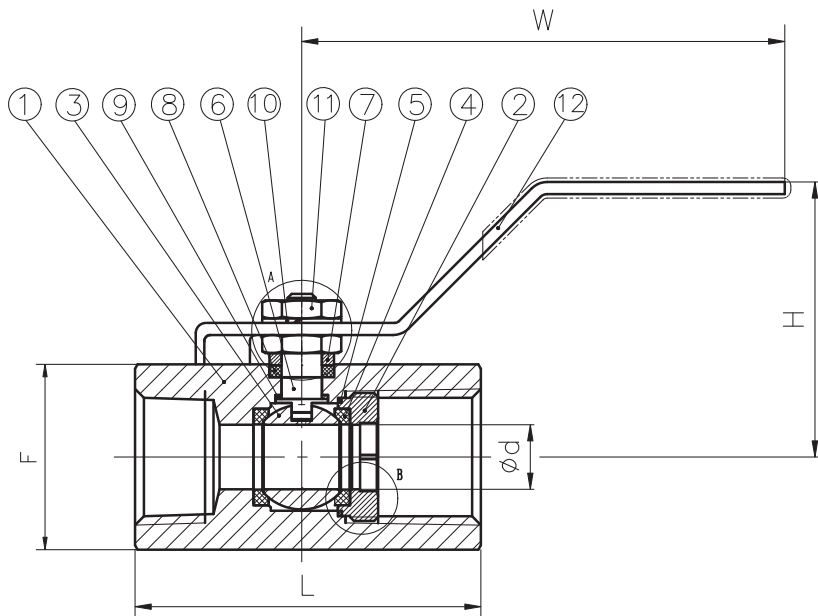
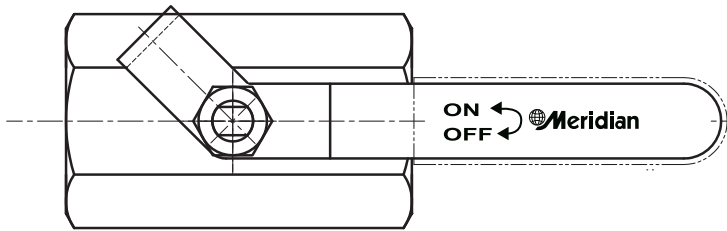

- ### FEATURES
- Threaded ends conform to ASME B1.20.1 (NPT)
 - Blow-out proof stem
 - CL 800 - 2000 WOG
 - Stainless steel ball and stem
 - Carbon filled PTFE seats
 - PTFE seal and packing
 - NACE MR01-75
 - Conforms to ASME B16.34
 - Pressure tested to API 598

ITEM	PARTS	MATERIAL
01	BODY	AISI A105N
02	SEAT RETAINER	AISI A105N
03	BALL	AISI 316
04	SEAT	RTFE
05	GASKET	PTFE
06	STEM	AISI 316
07	GLAND	AISI 304
08	PACKING	PTFE
09	THRUST WASHER	PTFE
10	SPRING WASHER	AISI 304
11	NUT	AISI 304
12	HANDLE	SS

DN	ød	L	W	H	F	Weight KG	Cv
8	5	43.2	78	31.8	21	0.12	2.5
10	7	47.2	80	33.8	25.4	0.17	4.5
15	9.2	62.5	118	55.4	30	0.35	7
20	12.5	69.9	118	61.5	36	0.49	9
25	16	85.9	135	65.3	46	0.97	16
32	20	93.7	146	74	55	1.46	24
40	24	101.6	146	78.7	61	1.71	37
50	32	114.3	152.5	119.4	75	2.9	68

NPS	ød	L	W	H	F	Weight Lb	Cv
1/4"	0.2	1.7	3.07	1.25	0.8	0.26	2.5
3/8"	0.28	1.86	3.15	1.33	1	0.37	4.5
1/2"	0.36	2.43	4.65	2.18	1.2	0.77	7
3/4"	0.49	2.75	4.65	2.42	1.4	1.08	9
1"	0.63	3.38	5.31	2.57	1.8	2.14	16
1-1/4"	0.79	3.69	5.75	2.9	2.2	3.22	24
1-1/2"	0.944	4	5.75	3.1	2.4	3.77	37
2"	1.26	4.5	6.00	4.7	2.9	6.39	68

