

3 PIECE FORGED TRUNNION BALL VALVE

Full and regular/reduced port

FEATURES & STANDARDS

- Industry leading warranty (48 months*)
- DBB (double block and bleed), DIB-1 (double isolation and bleed) & DIB-2 (combination seat options)
- DIB-1 drilled/tapped for pressure relief tie-in (most sizes)
- Triple independent low emission stem seals
- AED O-rings (anti-explosive decompression)
- Blow-out proof stem; double anti-static protection
- Consistent low torques with special wide seat
- Seat sealant injection system (smaller sizes use cavity injection) & emergency secondary stem sealant injection
- General Standards include: API 608, API 6D, ISO 17292, CSA Z245.15-13, CSA B51-09, ASME B16.34
- Sour service: NACE MR0175 & ISO 15156
- Fire safe design (API 607, ISO 10497 & API 6FA)
- SIL 3 certified (safety integrity level)
- Testing includes low pressure seat air test

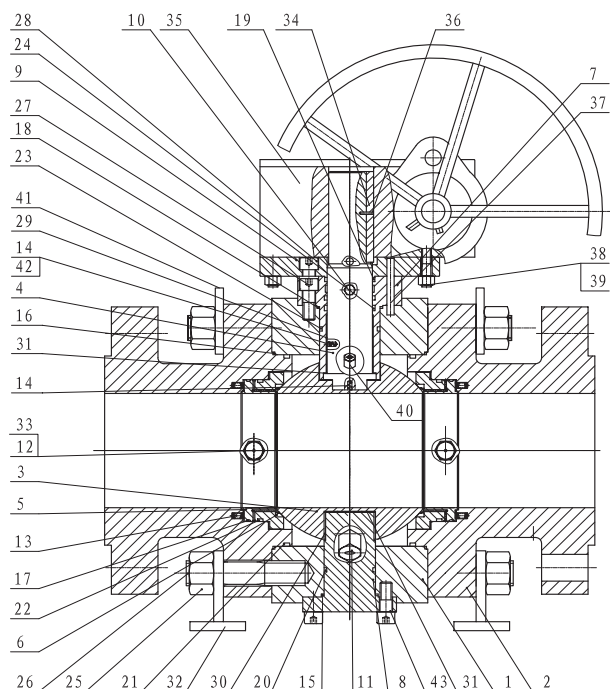

MANUFACTURING RANGE

(Available in full and regular port)

| Size | 150 ASME PN 20 | 300 ASME PN 50 | 600 ASME PN 100 | 900 ASME PN 150 | 1500 ASME PN 250 | 2500 ASME PN 420 |
|------|-------------------|-------------------|--------------------|--------------------|---------------------|---------------------|
| 2 | • | | | | | |
| 3 | • | | | | | |
| 4 | • | | | | | |
| 6 | • | | | | | |
| 8 | • | | | | | |
| 10 | • | | | | | |
| 12 | • | | | | | |
| 14 | • | | | | | |
| 16 | • | | | | | |
| 18 | • | | | | | |
| 20 | • | | | | | |
| 24 | • | | | | | |
| 30 | • | | | | | |
| 36 | • | | | | | |
| 42 | • | | | | | |
| 48 | • | | | | | |
| 56 | • | | | | | |

| ITEM | DESCRIPTIONS | ITEM | DESCRIPTIONS | ITEM | DESCRIPTIONS |
|------|-------------------------|------|-----------------------|------|-----------------|
| 1 | BODY | 16 | FIRE SAFE GASKET | 30 | BEARING |
| 2 | END CAP | 17 | FIRE SAFE GASKET | 31 | THRUST WASHER |
| 3 | BALL | 18 | FIRE SAFE GASKET | 32 | SUPPORT FEET |
| 4 | STEM | 19 | FIRE SAFE GASKET | 33 | CHECK VALVE |
| 5 | SEAT | 20 | TRUNNION SEAL O-RING | 34 | KEY |
| 6 | SEAT RING | 21 | BODY SEAL O-RING | 35 | GEAR OPERATOR |
| 7 | UPPER CAP | 22 | SEAT SEAL O-RING | 36 | PIN |
| 8 | TRUNNION | 23 | UPPER CAP SEAL O-RING | 37 | PIN |
| 9 | LIMIT STOP PLATE | 24 | STEM SEAL O-RING | 38 | STUD |
| 10 | SEALANT INJECTION VALVE | 25 | STUD | 39 | NUT |
| 11 | DRAIN VALVE | 26 | NUT | 40 | VENT VALVE |
| 12 | SEALANT INJECTION VALVE | 27 | ALLEN HEAD BOLT | 41 | LIFTING LUGS |
| 13 | SEAT SPRING | 28 | ALLEN HEAD BOLT | 42 | ANTISTATIC BALL |
| 14 | ANTISTATIC SPRING | 29 | BEARING | 43 | ALLEN HEAD BOLT |
| 15 | FIRE SAFE GASKET | | | | |

NOTE: Support legs and lifting lugs supplied on sizes 6" and larger.
 Drawings are representative, please contact Meridian for specific and current PDF drawings.
 * Meridian™ limited warranty of 48 months from date of shipment or 24 months from the date of start-up.